

The New !!

FULL HYDRAULIC 7.47 TONS DIESEL DRIVE WHEELED TYPE EXCAVATOR WITH
BLADE & BOOM SWING FUNCTIONS BUILT-IN

TB070W

Max. Dig Force : 4.8 Tons(Bucket)/3.6Tons(Arm)

Max. Dig Depth : 4035mm

Diesel Engine Output 56ps/2300rpm

Bucket Capa : 750mm Width/0.19 m³(Stuck):0.25 m³(SAE:Heaped)

Traction Speed : 1.7-6.5km/h (in working)

5.3-20.0km/h (in translation)

* Computer Engine Control for Efficient & Comfortable Work
and for Emergency!!

* Single Big Sized Main Cylinder with Front Visual Scope for
Deep & Powerful Digging!!



**SMALL UPPER SLEW
RADIUS & BIGGEST ENOUGH
WORKING RANGE**

* * Big Sized Blade for Outrigger & Efficient Ground Level
Work!!

* * Twin Tyred with Dozedr Blade helps Dynamic Stability
in Operating Work!!

* * At any digging position, excavator keeps dynamic
stability!!

TAKEUCHI

"TAKEUCHI" CREATING THE WAY IN URBAN CONSTRUCTION WORKSITES !!

HYDRAULIC 7.4H TON EXCAVATOR WITH DOZER BLADE & BOOM SWING FUNCTIONS BUILT-IN

TB070

OPERATING RANGES : mm

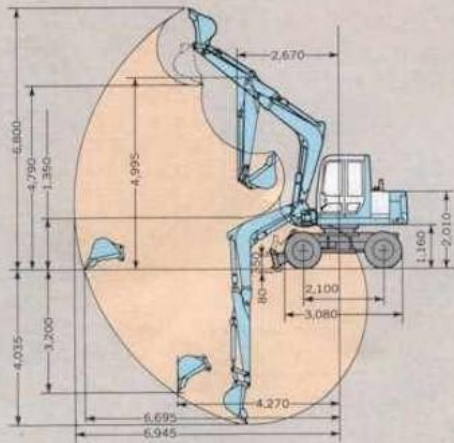

SINGLE TYRE : DOZER BLADE (FRONT) OUTRIGGER (REAR) TYPE TB070W (OPTION)



DIMENSION : mm

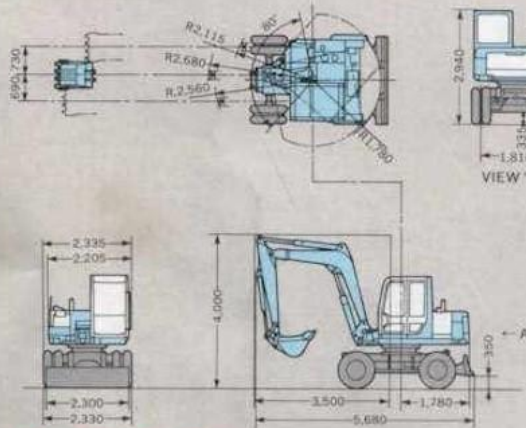

- * Side Light for Safety in the night time Upper Slew operation (in the darkness).
- * Covers Open/Close Layout for easy access for maintenance.
- * Minimized Noise from Clearance of Front Attachment : LH/RH Clearance Adjustment system at Bucket Pin & Plastic Made Thrust Washer.
- * Front Attachment Hoses Lay-Out to increase Front Visual Scope.
- * Engine Control in Finger Touch (Computer Electronics Control).
- * Button on Lever Grip for "One Touch Deceleration".
- * At ignition switch "ON", engine speed is automatically set to Rated RPM.
- * Engine Emergency Stop : Lub Oil Press Abnormal Drop.
- * Engine Emergency Idling : Cooling Water Temperature Abnormal Increase.
- * Two Steps Type Operator Seat for Most Comfortable Position.
- * Operator Seat Easy to use, and multi adjusting function equipped.
- * Comfortable Cabin with particularly better front upper scope.
- * Automatic Room Light "ON" in connection with Door-Opening. (Door Opening Position-Room Light "ON")

SPECIFICATION TB070W (CAB : WHEELED TYPE : BREAKER CIRCUIT PIPING STANDARD)

WEIGHT	Machine Operating Weight 7470kg	Rear Slew Radius 1780	Max. Dig Radius 6945
BUCKET	Bucket Capacity 0.19 _m (Stuck) / 0.25 _m (SAE Heaped)	Min. Ground Clearance 335	Max. Floor Dig Radius 6695
DIESEL ENGINE (WATER-COOLED)	Model BD3004 (Nissan) Type 4 Cylinder / 4 Cycle Rated Output 56PS/2300RPM Max. Torque 19kg.m/1800RPM Fuel Consumption 12.3 liter/h Cool Water Capacity 12.0 liter Displacement 2953cc Lubricating Oil Capacity 11 liter Fuel Tank Capacity 120liter	PERFORMANCES	Min. Slew Radius 2115(LH) / 2556(RH) (Swing) Max. Bucket Off-set 690(LH) / 730(RH)
OVERALL DIMENSIONS : mm	Length (in transport) 6270 Width 2335 Height 2940	Gradeability Working/Translating 35°/10.5° Max. Dig Power Bucket 4800kg.m Arm 3600kg.m	HYDRAULIC SYSTEM
		DOZER BLADE : mm	Pump Type Variable (P1+P2)+Gear (P3)+Gear (P4) Set Pressure 280x2+250x1+160x1 (kg/cm ²)
		BOOM SWING OFF-SET DIG FUNCTION	Discharge 68x2+43x1+14x1 (LPM) (VP1+VP2) (GP3) (GP4)
		Width x Height 2300x560 Operating Range 350 (Up) / 80 (Down) Swing Angle 80 (LH) / 50 (RH)	Breaker (One Way) & Service Port (Two Ways) 74LPM (VP1) Single Circuit Slew Motor Axial Piston Traction Motor Axial Piston Hydraulic Tank Capacity 68.0 liter
		OPERATING RANGE : mm	
		Max. Dig Depth 4035 Max. Vertical Dig Depth 3200 Max. Dump Height 4790 Max. Dig Height 6800	

OPTIONAL ATTACHMENT : ●TK8401 HYDRAULIC HAMMER : NON ACCM TYPE
"TAKEUCHI" BRANDED HYDRAULIC BREAKER HAMMAR WITH TOP MOUNT BRACKET POSSIBLE TO EQUIP WITH ONE TOUCH CONNECTION.
(SAME MODEL BREAKER AS EQUIPPED TO TB070 CRAWLER TYPE MODEL EXCAVATOR)